



Display and operating units

AZL66...

AZL66 display and operating units are used in connection with the LMV6 burner management system directly on the burner or in control cabinets within the burner's immediate vicinity.

- AZL66 units are used for the display, operation, and parameterization of specific safety-related and non-safety-related burner functions.
- Key plant data and fault codes can be queried and displayed.
- Communication between the AZL66 and the LMV6 takes place via the CAN interface.

The AZL66 and this data sheet are intended for original equipment manufacturers (OEMs) using the AZL66 in or on their products.

Use / Features

The description that follows reflects the maximum functional scope of the AZL66. The actual functions and the principle of operation are to be determined based on the LMV6.

- Housing in a modern design featuring recycled plastic
- Flame-retardant housing material
- Display of operating states, program phases, and fault codes
- Setting of parameters and ratio control curves
- Separate unit for front-panel installation
- With 4.3" TFT display
- With push-turn controller as central setting element
- With 2 additional buttons
- Many languages possible
- With USB port
- With LED to visualize the status of the burner
- Back-lit LCD (support dependent on LMV6)
- Fault display via an LED
- Backup function
- Housing designed for panel cut-out mounting (IP54 degree of protection when installed)

Supplementary documentation

Product type	Type of documentation	Documentation number
LMV60.110A2	User Documentation	A7560.1
	Data Sheet	N7560
	Basic Documentation	P7560
	Environmental Declaration	E7560 *)
AZL66	User Manual	U7562
	Environmental Declaration	E7562 *)

*) On request only

Warning notes



You will find additional safety instructions in the corresponding documentation for the LMV6.

To avoid personal injury or damage to property or the environment, the following warning notes must be observed.

- AZL66 units may only be used in building services plant and only in compliance with the applications described in this document.
- Compliance with all requirements described in the following chapters is a mandatory condition for using the AZL66.
- Local safety regulations (installation, etc.) must be complied with.
- It is not permitted to open AZL66 units. The warranty obligation shall become void if this requirement is violated.



Caution

It is not permitted to open, interfere with, or modify the AZL66.

- All activities (mounting, installation, service work, etc.) must be performed by qualified staff
- Before carrying out any wiring changes in the connection area, isolate the plant from the power supply (all-pole disconnection). Ensure that the plant cannot be inadvertently switched on again and that it is indeed dead. Failure to observe this information poses a risk of electric shock
- Take suitable measures to provide protection against accidental contact at the electrical connections. Failure to observe this information poses a risk of electric shock
- On completion of every task (mounting, installation, service work, shutdown, etc.) always check that the CAN interface is wired and connected correctly (RAST3.81 jack) in the AZL66 housing and that the parameter settings have been made correctly. Failure to observe this information poses a risk of damaging the safety functions and a risk of electric shock
- These AZL66 units must not be put into operation following impact or shock; even if they do not exhibit any visible damage, their safety functions may be impaired. Failure to observe this information poses a risk of damaging the safety functions and a risk of electric shock
- The burner or boiler manufacturer must ensure degree of protection IP40 / IP54 for the LMV6 and AZL66 as per DIN EN 60529. Failure to observe this information poses a risk of damaging the safety functions and a risk of electric shock

Siemens does not assume responsibility for damage resulting from unauthorized interventions.

Electromagnetic emissions must be checked on an application-specific basis!

Qualified personnel

Only **qualified personnel** are allowed to start up and operate the AZL66. Qualified personnel in the context of the safety-related notes contained in this data sheet are persons who are authorized to commission, ground, and tag units, systems, and electrical circuits in compliance with established safety practices and standards.

Correct use

Note the following:

The AZL66 may only be used for the applications described in the technical documentation and only in connection with Siemens burner management systems.

The AZL66 can only function correctly and safely if shipped, stored, set up, and installed correctly, and operated and maintained with care.

Mounting notes

- Ensure that the relevant national safety regulations and notes on standards are complied with
- Please note that the mounting surface must be completely flat
- The AZL66 must be used in a dry and clean environment
- Note the tightening torque of 0.5 Nm; this is a condition for compliance with IP54

Panel cut-out mounting of the AZL66

Step 1

Position the AZL66 in the correct place inside the designated opening (do not apply excess pressure).

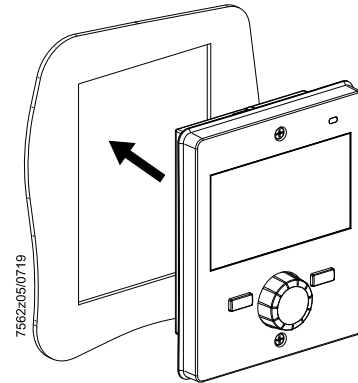

Step 2

Next, screw the AZL66 tight with the countersunk cross-head screws in the housing (do not apply excess pressure).



Note!
If the AZL66 does not fit inside the designated opening, check the cut-out and the housing.

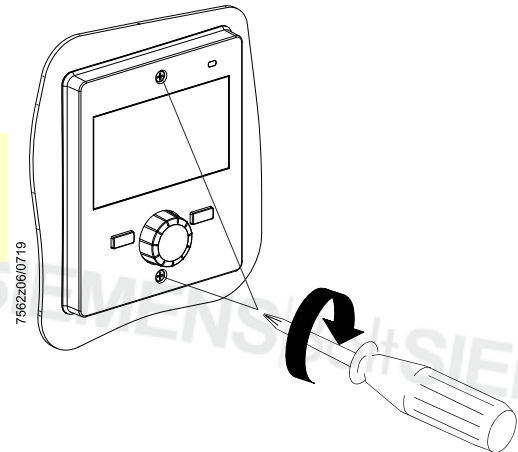

Cut-out dimensions for the AZL66

The AZL66 units are manufactured with installation dimensions of 90.1 x 125.7 mm ± 0.5 . The dimensions of the front panel result in a grid dimension of 90.5 mm. The mounting mechanisms enable the ALZ66 units to be installed in front panels of various thicknesses (1–3 mm).

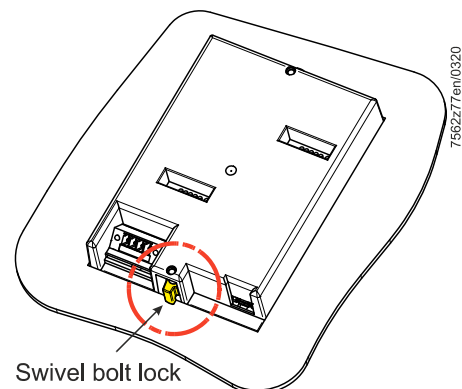
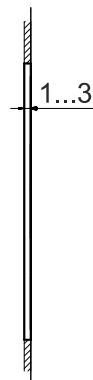
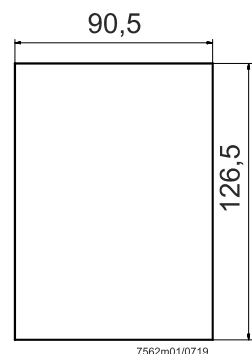



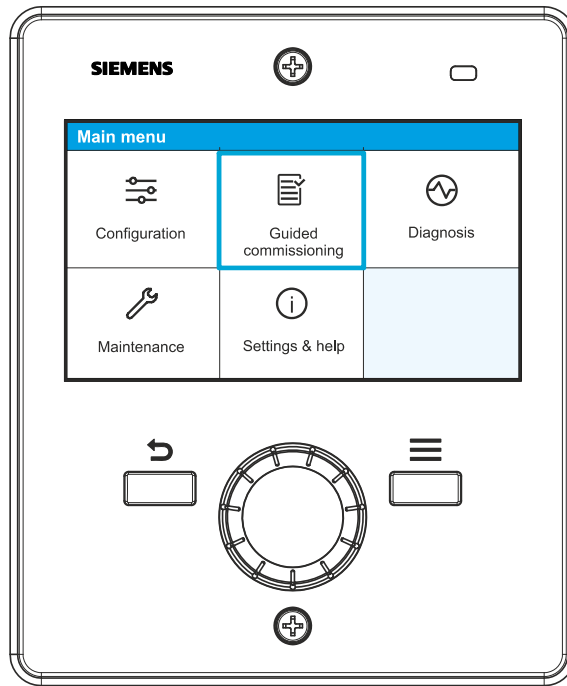

- Please note that the mounting surface must be completely flat
- The M4 screws with O-rings (such as those similar to 10-UNF) are equipped with a swivel bolt lock and are included in the scope of delivery of the AZL66

The operating philosophy and display philosophy can be found in the relevant user manuals for the LMV6. All unit versions of the AZL66 function and are operated in the same way.







Graphics	Function	Function
None	Rotary knob TURN	<ul style="list-style-type: none"> • Navigate through tile views or list views • Can be turned clockwise to the right or down • Can be turned counterclockwise to the left or up • Change parameter values
None	Rotary knob ENTER	<ul style="list-style-type: none"> • Select a tile / menu item • Confirm a change to a parameter value • Acknowledge messages
	Back (Return)	Exit a tile / menu item / value adjuster without making further changes
	Menu	<ul style="list-style-type: none"> • Jump to the top level of the menu tree (possible from anywhere) • Access to additional functions (if available)

Meaning of symbols on the display

Main menu		
 Configuration	 Guided commissioning	 Diagnosis
 Maintenance	 Settings & help	

7562z45en/0120

Tile	Meaning
 Configuration	<ul style="list-style-type: none"> • Changing parameters • Entering burner-specific parameters <p>Adaptation of programs and/or components/accessories to the LMV6 and adaptation of the LMV6 to its components/accessories.</p>
 Guided commissioning	Central repository of all relevant parameters for commissioning
 Maintenance	Maintenance prompt message. Maintenance is carried out at regular intervals by trained specialist personnel. The most important information required by the heating engineer to carry out maintenance is stored here.
 Diagnosis	Repository for error and fault history
 Settings & help	<ul style="list-style-type: none"> • Entering the password • Changing the language (default: English)

- AGG6.635 signal cable from the LMV6 to the AZL66. The AGG6.635 signal cable is specified for use under the burner hood. If other signal cables are used, there is no guarantee that the required cable features will be available.
- Lay the AGG6.635 signal cable from the LMV6 to the AZL66 separately from other cables.
- Both the AGG6.635 signal cable and the AZL66 must be shipped and stored so that no damage due to dust and water can occur during subsequent use in the plant.
- Prior to switching on the mains voltage, make certain that the AGG6.635 signal cable has been connected to the AZL66 correctly.
- The AZL66 must be used in a dry and clean environment.
- The electrical power supply must be disconnected prior to installation.
- The requirements of protection class II must be observed for the wiring.
- Static charges must be avoided since they can damage the electronic components of the AZL66 on contact.

Recommendation: Use ESD equipment!



Caution

- DIN EN 60335 and DIN EN 60730-2-5 must be complied with
- Ensure that the electrical wiring inside the boiler complies with national and local regulations.
- The burner or boiler manufacturer must ensure degree of protection IP40 / IP54 for the LMV6 and AZL66 as per DIN EN 60529. Failure to observe this information poses a risk of damaging the safety functions and a risk of electric shock

Commissioning notes

Prerequisites

The burner or boiler manufacturer is responsible for parameterizing the LMV6 correctly; this involves compliance with the relevant standards and guidelines.

Standards and certificates



Note!
Only in connection with the LMV6!



ISO 9001:2015
ISO 14001:2015
OHSAS 18001:2007



China RoHS
Hazardous substances table:
<http://www.siemens.com/download?A6V10883536>

Disposal notes

The AZL66 contains electrical and electronic components and must not be disposed of together with domestic waste. Local and currently valid legislation must be complied with.

Open Source Software (OSS) declaration

Due to the license terms of the software we use, Siemens AG wishes to note that the OEM is obligated to provide the following license text for the end user in the documentation:

Open Source Software (OSS) declaration

Embedded in – or bundled with – the AZL66 are open source software (OSS) components and other third-party components identified below. You will find the specific product type and the valid version in the OSS document.

Title: Readme_OSS AZL66 V01.

You may obtain, distribute, and/or modify a copy of the open source code for the component under the terms of their respective licenses. These may be a GNU General Public License, the GNU Lesser General Public License, a modified BSD license, or an MIT license. In the event of conflicts between Siemens license conditions and the open source software license conditions, the open source software conditions shall prevail with respect to the open source software portions of the software.

You are permitted to modify proprietary components originating from Siemens and make changes as part of a reverse engineering process for debugging purposes, to the extent that these are linked to libraries licensed under the GNU Lesser General Public License.

You are not permitted to distribute information resulting from this reverse engineering process of from the modified proprietary components. Your rights to modify proprietary components originating from parties other than Siemens are governed by the respective third-party license conditions.

On written request within three years from the date of product purchase and against payment of our expenses, Siemens will supply the source code for any OSS component identified below in line with the terms of the applicable license.

Please contact us in this regard at:

Siemens AG
Otto-Hahn-Ring 6
81739 Munich
Germany
Reference: Open Source Request

The identified OSS components are generally distributed in the hope that they will be useful, but WITHOUT ANY WARRANTY, without even implied warranty of merchantability or FITNESS FOR A PARTICULAR PURPOSE, and without liability for any Siemens entity other than as explicitly documented in your purchase contract.

All open source software components used within the product (including their copyright holders and the license conditions) can be found on the website at <http://www.siemens.com/download?A6V11985972>.

Type summary

Type	AZL66.00A8
Article no.	S55629-H301-A100
Functions	
Graphic display (4.3" TFT with 480 x 272 pixels)	●
Parameter-setting functions and display functions	●
Saving of fault histories and error histories	●
Reset	●
Burner rapid shutdown using button combinations	●
3 access levels, 2 of which have password protection	●
Parameter backup function	●

Technical data

General unit data

Supply voltage	24 V DC -15% / +10%
Power consumption	< 5 W, typically
Degree of protection	
• Rear	IP00 in accordance with DIN EN 60529
• Front	IP54 in accordance with DIN EN 60529 when installed
Protection class	II in accordance with DIN EN 60730-1
Housing	
• Material	PC and PC / ABS
• Color	RAL 7035 (light gray)
Flammability rating	
• Clear housing parts	According to UL94 V2 (PC)
• Dyed housing parts	According to UL94 V0 (PC / ABS)
Weight	Approx. 260 g
Pollution degree	2
Tightening torque for fixing screws	Max. 0.5 Nm
Cut-out dimensions	90.1 x 125.7 mm ±0.5

AGG6.635 signal cable Display → BCI

Signal cable	White in color Shielded With RAST3.81 connector
Cable length	3 m
Place of installation	Under the burner hood (arrangements for SKII EN 60730-1 additionally required)

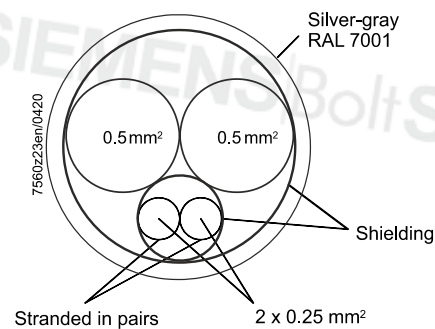

Connection	Color	Wire cross-section in mm ²
24 V DC 1	White	0.5
24 V DC 2	Brown	0.5
CANH	Yellow	0.25
CANL	Green	0.25

The permissible cable length is specified in the data sheet for the LMV6.

Inputs/outputs

CAN interface with RAST3.81 jack	To Siemens LMV6 burner management system
----------------------------------	--

Technical data (continued)

Environmental conditions

Storage	DIN EN 60721-3-1
Climatic conditions	Class 1K3
Mechanical conditions	Class 1M2
Temperature range	-20 to +60°C
Humidity	< 95% r.h.
Transport	DIN EN 60721-3-2
Climatic conditions	Class 2K3
Mechanical conditions	Class 2M2
Temperature range	-20 to +60°C
Humidity	< 95% r.h.
Operation	DIN EN 60721-3-3
Climatic conditions	Class 3K3
Mechanical conditions	Class 3M3
Temperature range	-20 to +60°C
Humidity	< 95% r.h.
Installation altitude	Max. 2,000 m above sea level



Warning!

Condensation, formation of ice, and ingress of water are not permitted. Failure to observe this information poses a risk of damaging the safety functions and a risk of electric shock.

Connection diagram

Example: Basic diagram of AZL66 with LMV6

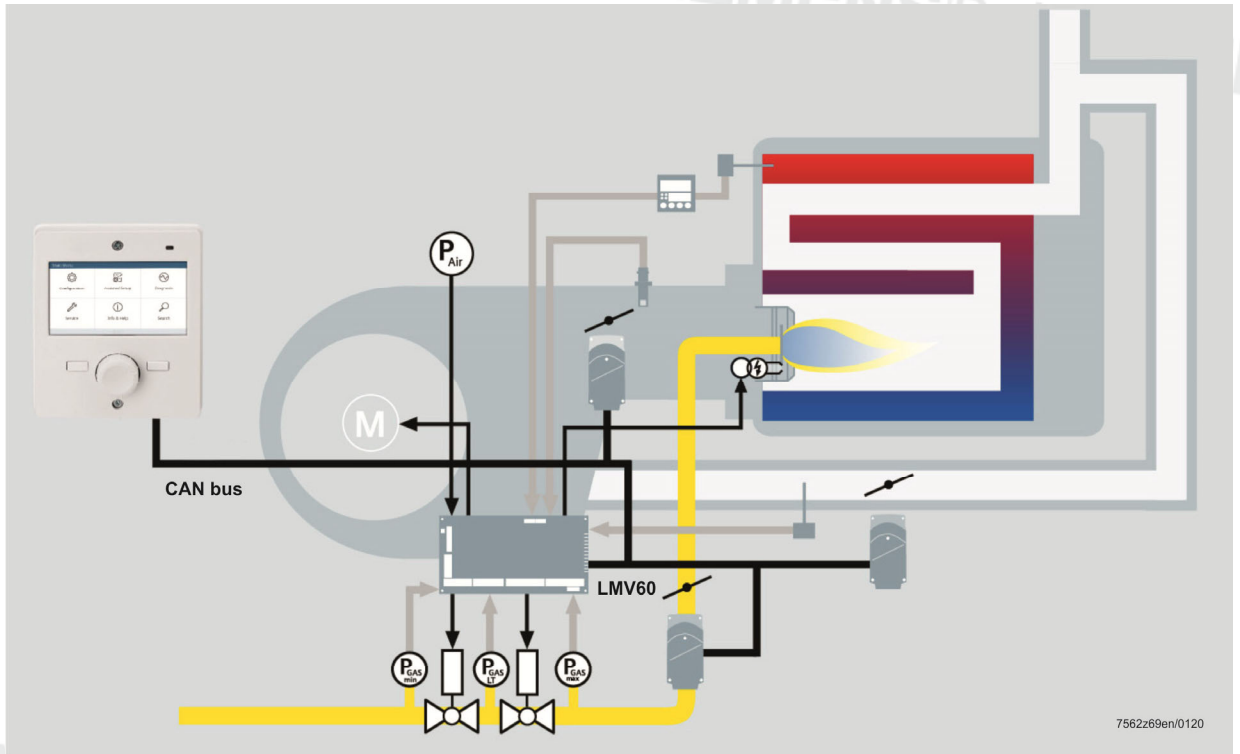

Connection, AZL66 to LMV6

AZL66

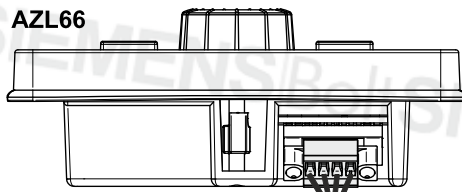

AGG6.635 Signal cable

LMV6

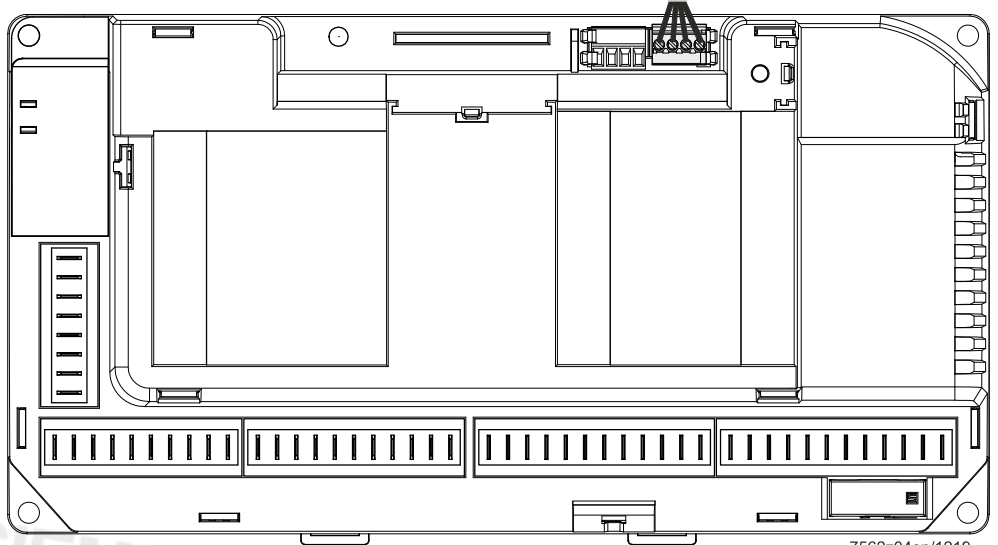

7562z04en/1219

Dimensions

Dimensions in mm

AZL66

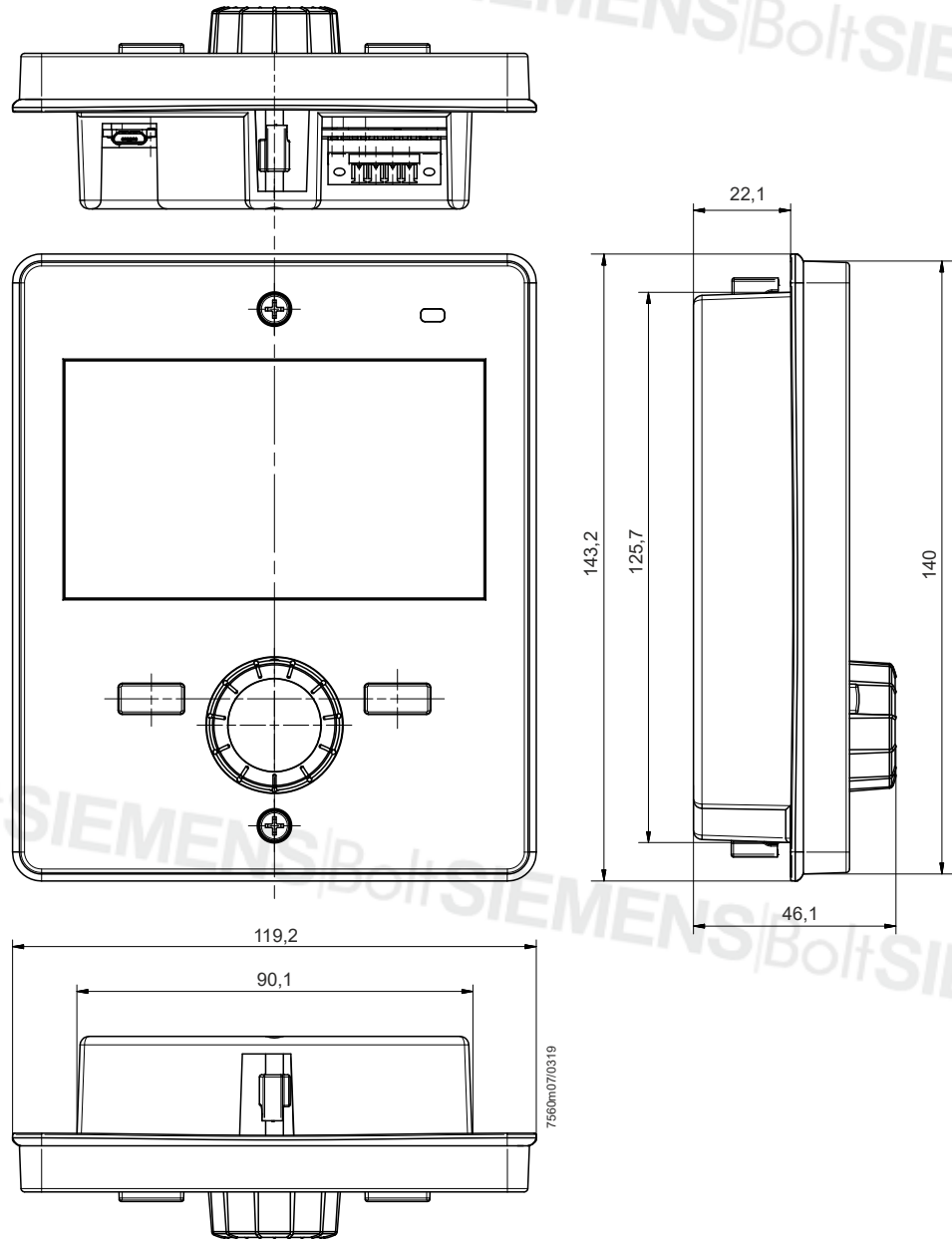

M1:2

